



Client _____ Quantity _____
Project _____ Position _____

FUN 700

Electric range, 2 square plates, on open cabinet

Model: F70/40PCEQ/A

Cod: MP01012123005

Technical data

Modularity:	On open cabinet
Dimension (mm):	400x700x850 mm
Total electric power (kW):	5,2
Electric power (V):	380-415
Ampere (A):	12
Phases:	3N
Cable section (mmq):	5G1,5
Frequency (Hz):	50-60
Net volume (m3):	0,238
Packing dimensions (mm):	477x776x1147 mm
Gross weight (Kg):	42
Gross volume (m3):	0,425

Features

Working top:	Realizzato in acciaio inox AISI 304 con spessore 10/10 mm
Knobs:	Knobs are made from a sturdy heat-resistant polymer blend and are equipped with liquid anti-leakage washer

Technical draw

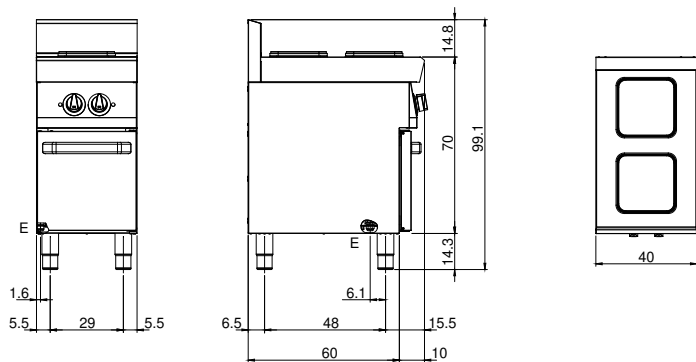

E: Electric power