



Client _____ Quantity _____
 Project _____ Position _____

FUN 700

Gas range enamelled containers, 4 burners, electric convection oven

Model: F70/70CFGEB

Cod: MP01032133000

Technical data

Modularity:	Electric oven
Dimension (mm):	700x700x850 mm
Dimensione forno (mm):	565x330x325
Total electric power (kW):	3,96
Total gas power (Kcal/h):	15822
Total gas power (kW):	18,4
Oven type:	Electric convection oven
Oven power (kW):	3,96
Oven temperature range (°C):	50-300
Gas connection:	1/2"
Electric power (V):	380-415
Ampere (A):	6,5
Phases:	3N
Cable section (mmq):	5G1,5
Frequency (Hz):	50
Net volume (m3):	0,417
Packing dimensions (mm):	776x776x1180 mm
Gross weight (Kg):	95
Burner power 1 (kW):	5,5
Burner power 2 (kW):	3,7
Burner power 3 (kW):	5,5
Burner power 4 (kW):	3,7
Gross volume (m3):	0,711

Features

Burners:	Double or single crown cast iron version available with a pilot light
Grill:	Cast-iron with brass single- and double-crown burner with pilot
Working top:	Made of AISI 304 stainless steel with a thickness of 10/10 mm and removable enamelled containers
Knobs:	Knobs are made from a sturdy heat-resistant polymer blend and are equipped with liquid anti-leakage washer
Handles:	Brushed aluminum finish
Kit Gas:	natural gas conversion kit 30/50 m/bar (tested with natural gas G20)

Technical draw

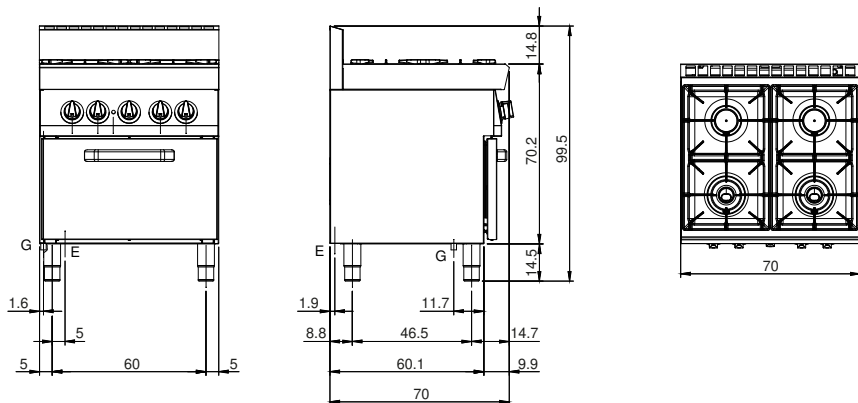

G: Gas connection 1/2"

E: Electric power