

Client \_\_\_\_\_ Quantity \_\_\_\_\_  
 Project \_\_\_\_\_ Position \_\_\_\_\_

## Technical data

<b>Modularity:</b>	Electric oven
<b>Dimension (mm):</b>	1100x700x850 mm
<b>Dimensione forno (mm):</b>	565x330x325
<b>Total electric power (kW):</b>	3,96
<b>Total gas power (Kcal/h):</b>	22184
<b>Total gas power (kW):</b>	25,8
<b>Oven type:</b>	Electric convection oven
<b>Oven power (kW):</b>	3,96
<b>Oven temperature range (°C):</b>	50-300
<b>Gas connection:</b>	1/2"
<b>Electric power (V):</b>	380-415
<b>Ampere (A):</b>	6,5
<b>Phases:</b>	3N
<b>Frequency (Hz):</b>	50
<b>Net volume (m3):</b>	0,655
<b>Packing dimensions (mm):</b>	1176x776x1180 mm
<b>Gross weight (Kg):</b>	131
<b>Burner power 1 (kW):</b>	5,5
<b>Burner power 2 (kW):</b>	3,7
<b>Burner power 3 (kW):</b>	3,7
<b>Burner power 4 (kW):</b>	3,7
<b>Gross volume (m3):</b>	1,077

## FUN 700

Gas range enamelled containers, 6 burners, electric convection oven

**Model:** F70/110CFGEB

**Cod:** MP01032133002

## Features

<b>Burners:</b>	Double or single crown cast iron version available with a pilot light
<b>Grill:</b>	Cast-iron with brass single- and double-crown burner with pilot
<b>Working top:</b>	Made of AISI 304 stainless steel with a thickness of 10/10 mm and removable enamelled containers
<b>Knobs:</b>	Knobs are made from a sturdy heat-resistant polymer blend and are equipped with liquid anti-leakage washer
<b>Handles:</b>	Brushed aluminum finish
<b>Kit Gas:</b>	natural gas conversion kit 30/50 m/bar (tested with natural gas G20)

**Technical draw**

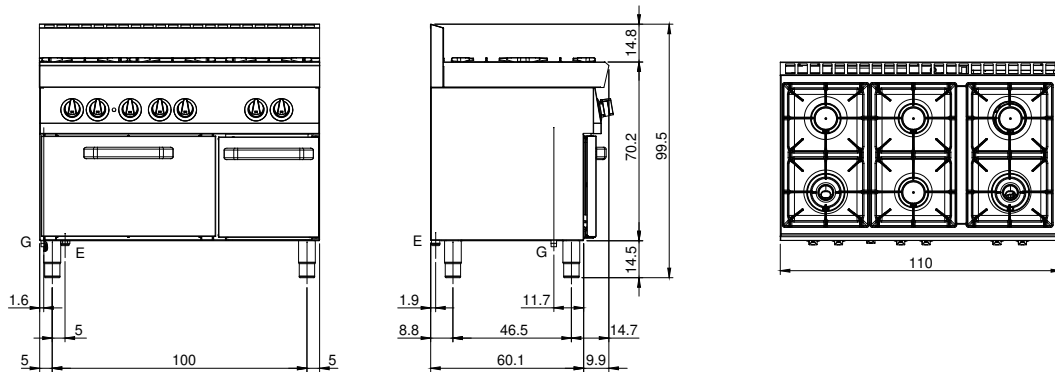

**G:** Gas connection 1/2"

**E:** Electric power