



Client \_\_\_\_\_ Quantity \_\_\_\_\_  
 Project \_\_\_\_\_ Position \_\_\_\_\_

**FUN 700**

Electric griddle, ribbed chromed plate, on cabinet with door

**Model:** F70/40FTE/CR/P

**Cod:** MP01372123023

**Technical data**

<b>Modularity:</b>	On cabinet with door
<b>Dimension (mm):</b>	400x700x850
<b>Total electric power (kW):</b>	4,5
<b>Cooking zone dimensions 1 (LxD mm):</b>	396x520
<b>Electric power (V):</b>	380-415
<b>Ampere (A):</b>	7
<b>Phases:</b>	3N
<b>Cable section (mmq):</b>	5G1,5
<b>Frequency (Hz):</b>	50-60
<b>Net volume (m3):</b>	0,238
<b>Packing dimensions (mm):</b>	477x776x1147
<b>Gross weight (Kg):</b>	60
<b>Gross volume (m3):</b>	0,425

**Features**

<b>Working top:</b>	Realizzato in acciaio inox AISI 304 con spessore 10/10 mm
<b>Material of plate:</b>	Chrome
<b>Plate finish:</b>	Ribbed
<b>Knobs:</b>	Knobs are made from a sturdy heat-resistant polymer blend and are equipped with liquid anti-leakage washer
<b>Handles:</b>	Brushed aluminum finish
<b>Plate:</b>	Chromed

In order to constantly offer the best possible products we reserve the right to make changes on technical specifications without incurring any obligation for equipment previously or subsequently sold.

Technical draw

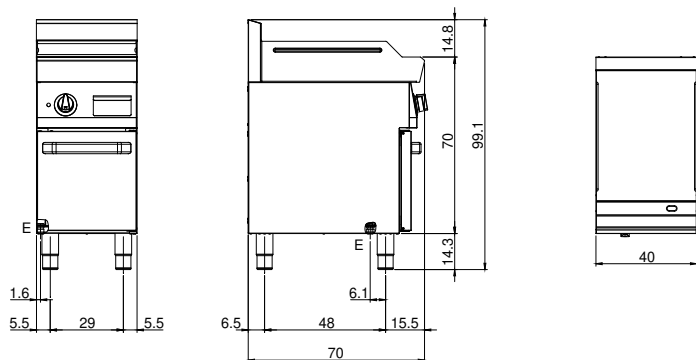

E: Electric power