



Client \_\_\_\_\_ Quantity \_\_\_\_\_  
Project \_\_\_\_\_ Position \_\_\_\_\_

## FUN 700

Electric griddle, 2/3 smooth 1/3 ribbed chromed plate, on open cabinet

**Model:** F70/70FTE/CLR/A      **Cod:** MP01372123015

### Technical data

<b>Modularity:</b>	On open cabinet
<b>Dimension (mm):</b>	700x700x850
<b>Total electric power (kW):</b>	9
<b>Cooking zone dimensions 1 (LxD mm):</b>	696x520
<b>Electric power (V):</b>	380-415
<b>Ampere (A):</b>	14
<b>Phases:</b>	3N
<b>Cable section (mmq):</b>	5G2,5
<b>Frequency (Hz):</b>	50-60
<b>Net volume (m3):</b>	0,417
<b>Packing dimensions (mm):</b>	776x776x1180
<b>Gross weight (Kg):</b>	103
<b>Gross volume (m3):</b>	0,711

### Features

<b>Working top:</b>	Realizzato in acciaio inox AISI 304 con spessore 10/10 mm
<b>Material of plate:</b>	Chrome
<b>Knobs:</b>	Knobs are made from a sturdy heat-resistant polymer blend and are equipped with liquid anti-leakage washer
<b>Plate:</b>	Chromed

Technical draw

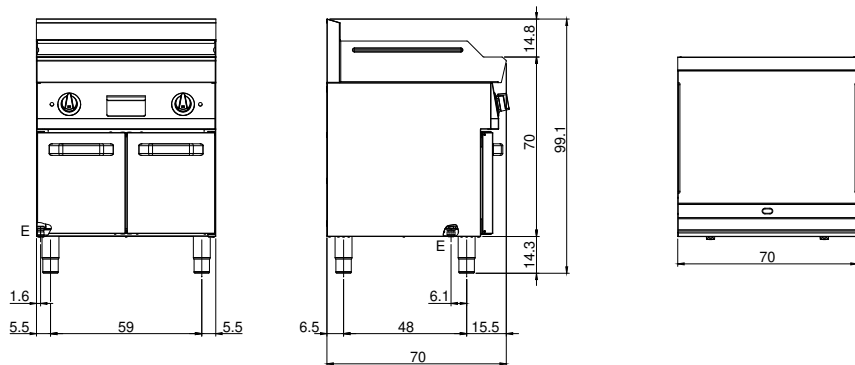

E: Electric power